

A

- WAS001-W | WAS002-W | WAS003-W | VA001-W
- WAS004-Z | WAS005-Z | WAS006-Z | VA002-Z

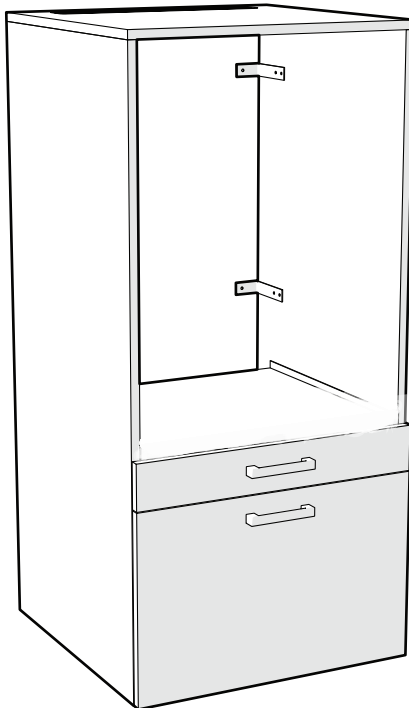

Ⓧ Bevor Sie mit der Montage beginnen, folgen Sie bitte Schritt für Schritt dieser Montageanleitung.

Ⓧ Before starting assembly, follow these assembly instructions step by step.

Ⓧ Voordat u begint met monteren, volg deze montagehandleiding stapsgewijs.

Ⓧ Avant de commencer le montage, suivez ces instructions de montage étape par étape.



DE **WARNUNG!**

Bevor Sie mit der Montage beginnen und die Möbel an der Wand aufhängen oder befestigen (um sie vor dem Umfallen zu schützen), sollten Sie zunächst die Art und Stabilität der Wand beurteilen. Achtung: Das mitgelieferte Befestigungsmaterial (Dübel und Schrauben) ist nur für Beton und Massivwände geeignet. Wenden Sie sich an einen Fachmann, um sich über geeignete Befestigungsmaterialien beraten zu lassen, und verwenden Sie Dübel und Schrauben, die für die jeweilige Wandart geeignet sind. Die Montage sollte von einer fachkundigen Person durchgeführt werden. Er ist notwendig die Eignung des Unterbodens zu prüfen. Sollten Sie hieran Zweifel haben oder Fragen dazu haben, wenden Sie sich bitte an unseren Kundendienst. Bitte beachten Sie, dass bei Nichtbeachtung der Montageanleitung es zu einer fehlerhaften Montage kommen kann. Lesen Sie die Anleitung der Waschmaschine selbst sorgfältig durch und befolgen Sie die Anweisungen des Geräteherstellers.



EN **WARNING!**

Before starting the assembly and hanging or fixing the furniture to the wall (to protect it from falling over), first assess the type and stability of the wall. Caution : The fixing materials supplied (plugs and screws) are only suitable for concrete and solid walls. For advice on suitable fixing materials, contact a specialist and use plugs and screws suitable for the type of wall. Mounting should be carried out by someone knowledgeable. It is necessary to check the suitability of the subfloor. If you have any questions about this, please contact our customer service team. Please note that by not following these assembly instructions step by step, it may lead to incorrect installation. Carefully read the assembly for the washing machine itself and follow the appliance manufacturer's instructions.



NL **WAARSCHUWING!**

Voordat u aan de montage begint en het meubel ophangt of bevestigt tegen de muur (dit om het meubel te beschermen tegen omvallen), beoordeel eerst het type en de stabiliteit van de muur. Let op: de meegeleverde bevestigingsmaterialen (pluggen en schroeven), zijn alléén geschikt voor betonnen en massieve muren. Voor advies over geschikte bevestigingsmaterialen, neem contact op met een specialist en maak gebruik van pluggen en schroeven die geschikt zijn voor het type muur. De montage dient door iemand met kennis van zaken worden uitgevoerd. Het is noodzakelijk de geschiktheid van de ondervloer te controleren. Let op: bij het niet stapsgewijs volgen van deze montagehandleiding, kan dit leiden tot een verkeerde montage. Lees ook zorgvuldig de handleiding van de wasmachine zelf en volg de instructies van de fabrikant van het apparaat op.



FR AVERTISSEMENT!

Avant de commencer le montage et d'accrocher ou de fixer le meuble au mur (pour le protéger des chutes), vérifiez d'abord le type et la stabilité du mur. Attention : Le matériel de fixation fourni (chevilles et vis) ne convient qu'au béton et aux murs pleins. Pour obtenir des conseils sur les matériaux de fixation appropriés, contactez un spécialiste et utilisez des chevilles et des vis adaptées au type de mur. Le montage doit être effectué par une personne compétente.



**DE KONFIGURATIONEN / EN CONFIGURATIONS /
NL CONFIGURATIES / FR CONFIGURATIONS**

PREMIUM



PREMIUM ONE
205 cm

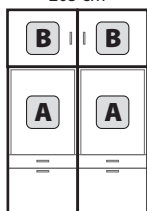

ELITE
205 cm

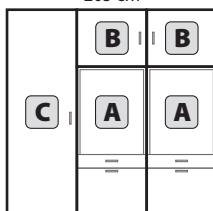

ROYALLETTE
205 cm

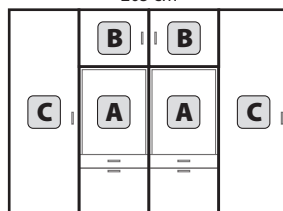

PREMIUM ONE
240 cm



ELITE
240 cm

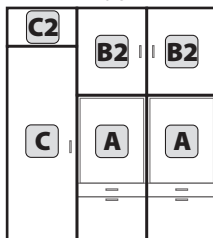

ROYALLETTE
240 cm

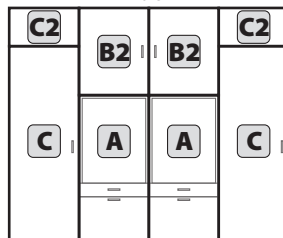

A ○ WAS001-W | WAS002-W | WAS003-W | VA001-W
● WAS004-Z | WAS005-Z | WAS006-Z | VA002-Z

B ○ U01-W
● U02-Z

B2 ○ U03-W | U04-W
● U05-Z | U06-Z

C ○ HG001-W | HG002-W | HG003-W
● HG004-Z | HG005-Z | HG006-Z

C2 ○ OP01-W
● OP02-Z



3,5 x 30

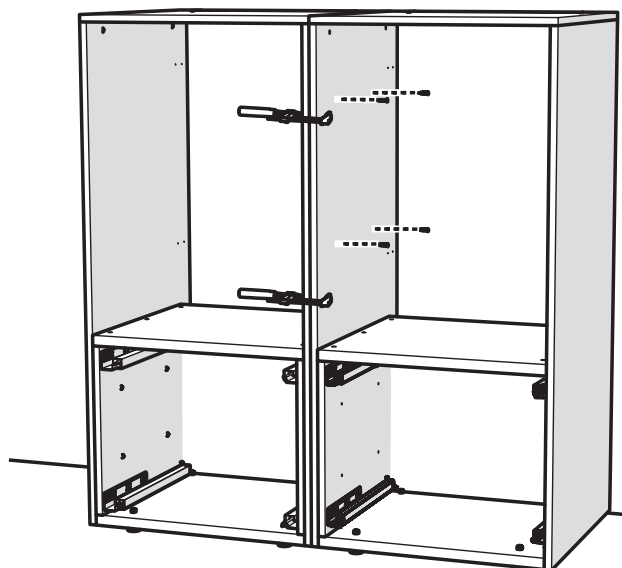



DE TECHNISCHE DATEN / EN SPECIFICATIONS /
NL SPECIFICATIES / FR SPÉCIFICATIONS

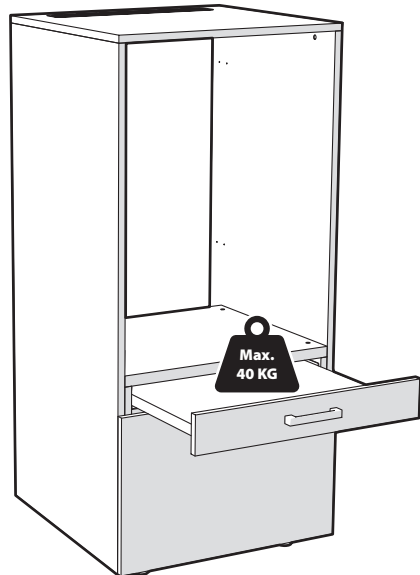
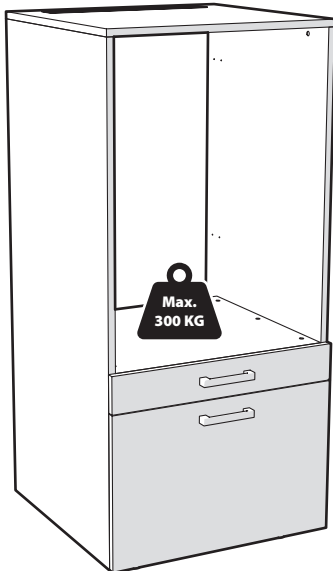
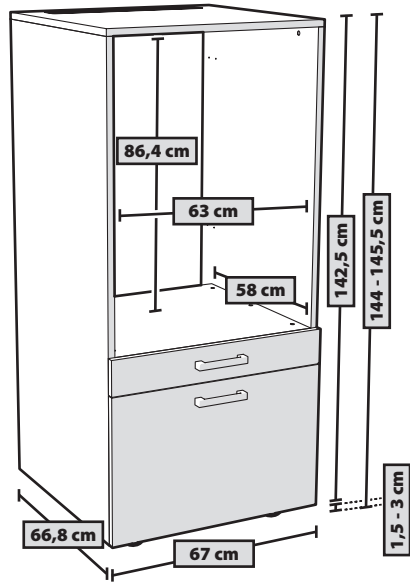
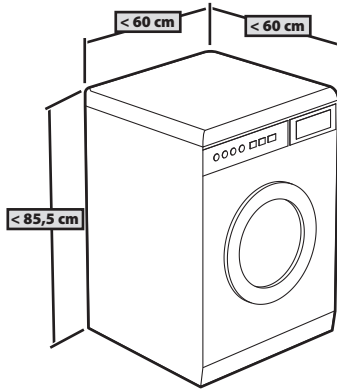



DE INSTALLATION / EN INSTALLATION / NL INSTALLATIE /
FR INSTALLATION

A

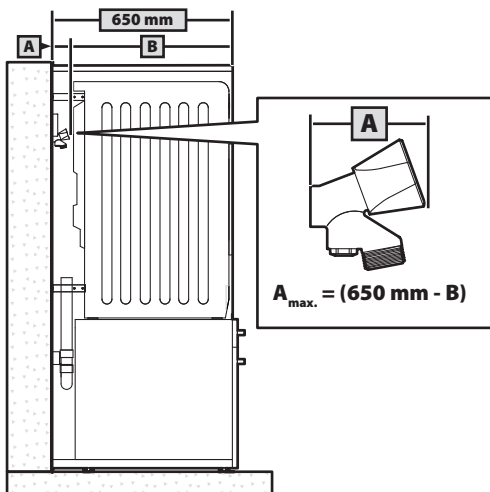

B

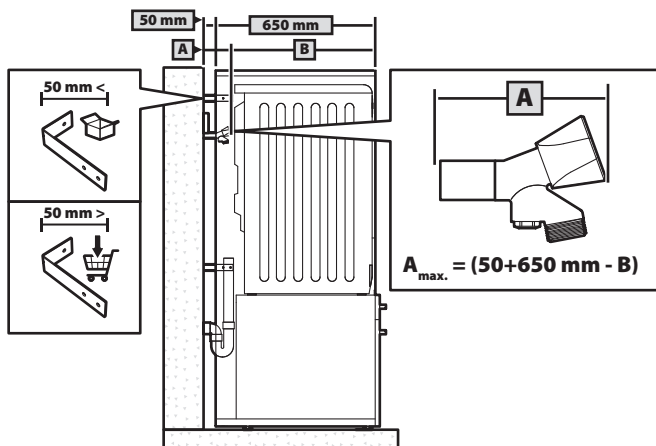

C

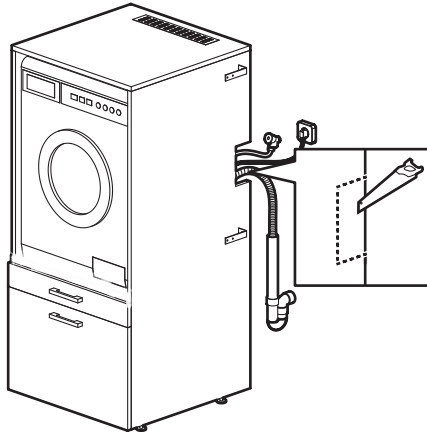

D

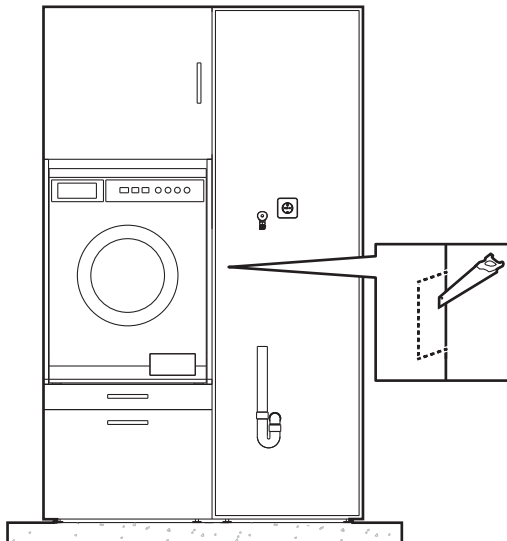



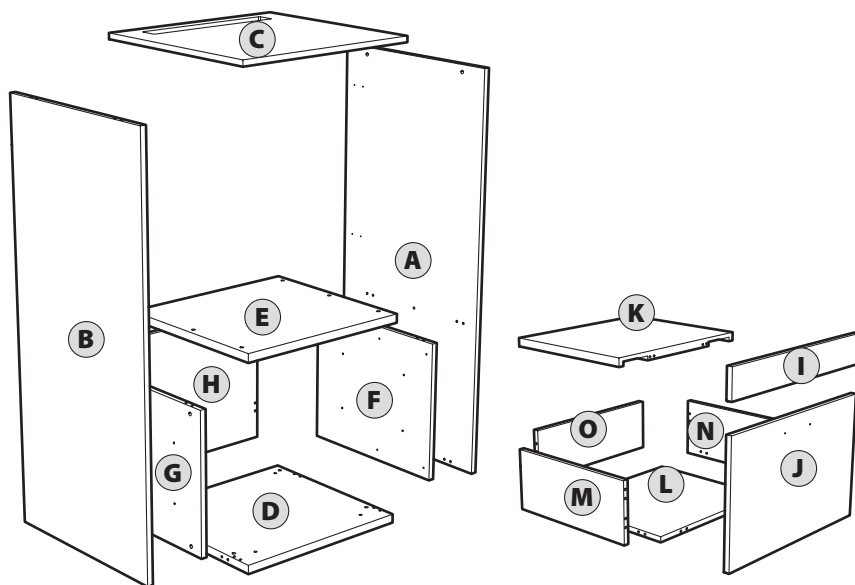











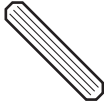

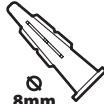

(DE) INHALT DER VERPAKKUNG / (EN) CONTENT OF THE PACKAGING
 / (NL) INHOUD VAN DE VERPAKKING / (FR) CONTENU DE
 L'EMBALLAGE

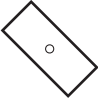





WAS001-W / WAS004-Z	A	B							
WAS002-W / WAS005-Z	C	F	G	I	J	L	M	N	O
WAS003-W / WAS006-Z	D	E	H	K					
VA001-W / VA002-Z									

WAS002-W / WAS005-Z

<p>4×</p>  <p>10011</p>	<p>4×</p>  <p>10012</p>	<p>4×</p>  <p>M13</p> <p>10013</p>	<p>4×</p>  <p>10046</p>	<p>40×</p>  <p>10014</p>	<p>40×</p>  <p>10015</p>
<p>22×</p>  <p>10016</p>	<p>40×</p>  <p>10017</p>	<p>32×</p>  <p>3,5 × 16</p> <p>10018</p>	<p>8×</p>  <p>3,5 × 30</p> <p>10019</p>	<p>4×</p>  <p>4 × 22</p> <p>10020</p>	<p>4×</p>  <p>5 × 70</p> <p>10021</p>
<p>4×</p>  <p>8mm</p> <p>10022</p>	<p>4×</p>  <p>10023</p>	<p>4×</p>  <p>10024</p>	<p>2×</p>  <p>10025</p>	<p>1×</p>  <p>L</p> <p>10026</p>	<p>1×</p>  <p>R</p> <p>10027</p>
<p>1×</p>  <p>L</p> <p>10028</p>	<p>1×</p>  <p>R</p> <p>10029</p>	<p>1×</p>  <p>10030</p>			

WAS003-W / WAS006-Z

<p>1×</p>  <p>L</p> <p>10026</p>	<p>1×</p>  <p>R</p> <p>10027</p>	<p>1×</p>  <p>L</p> <p>10028</p>	<p>1×</p>  <p>R</p> <p>10029</p>		
---	---	---	---	--	--

DE WERKZEUGE / EN TOOLS / NL BENODIGDHEDEN / FR OUTILS

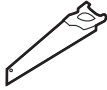
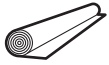
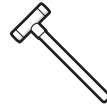

DE TIPPS / EN TIPS / NL TIPS / FR CONSEILS



DE BEFESTIGUNGSMETHODEN / EN FIXING METHODS /
NL BEVESTIGINGSMETHODES / FR MÉTHODES DE FIXATION

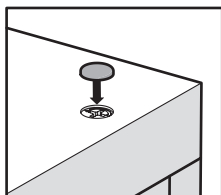
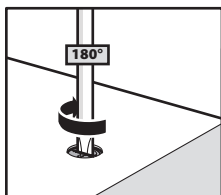
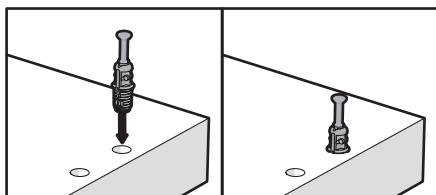
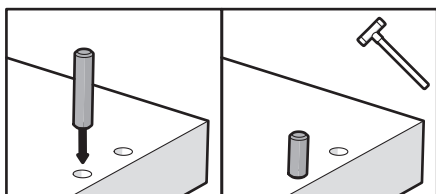
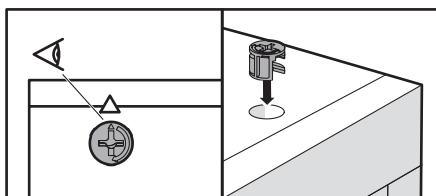

1

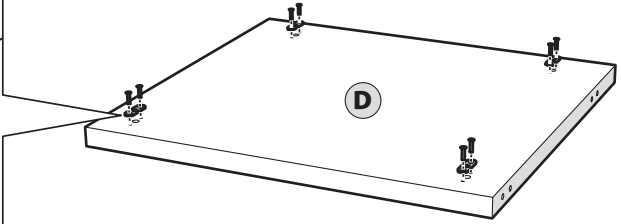
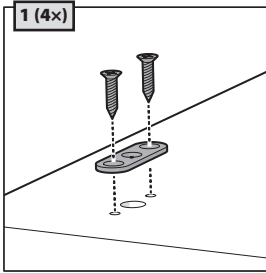
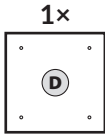

2

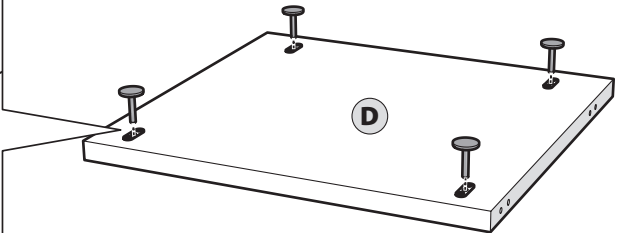
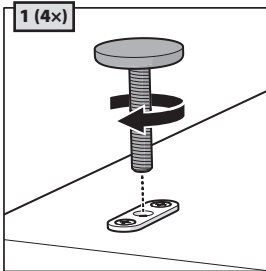

3

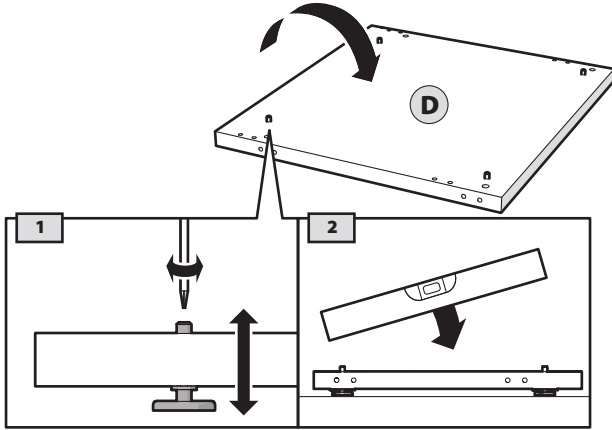
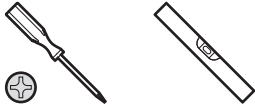

4

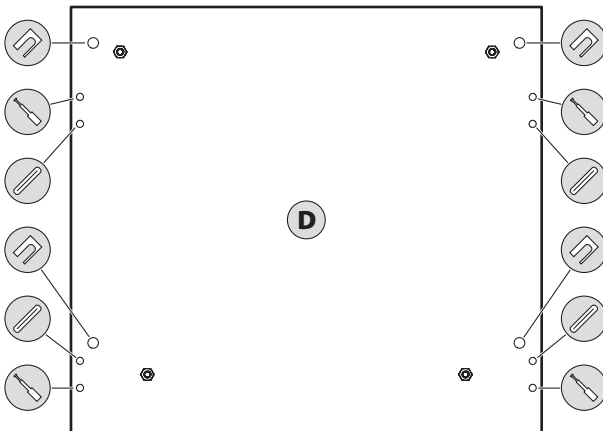
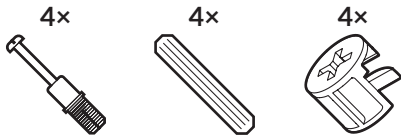

5

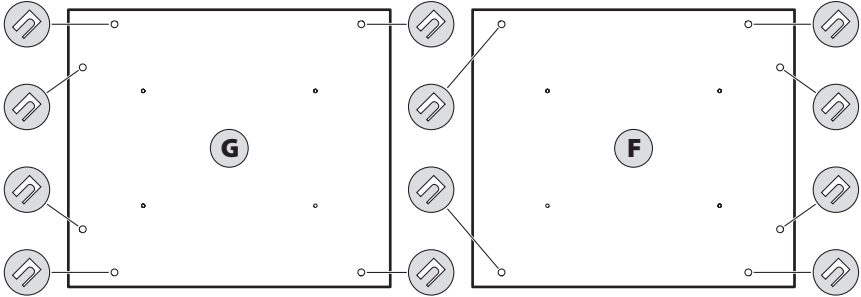
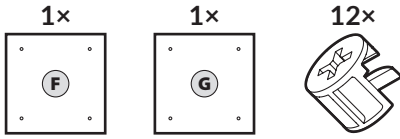

6

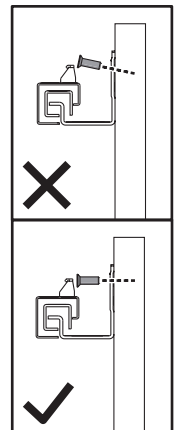
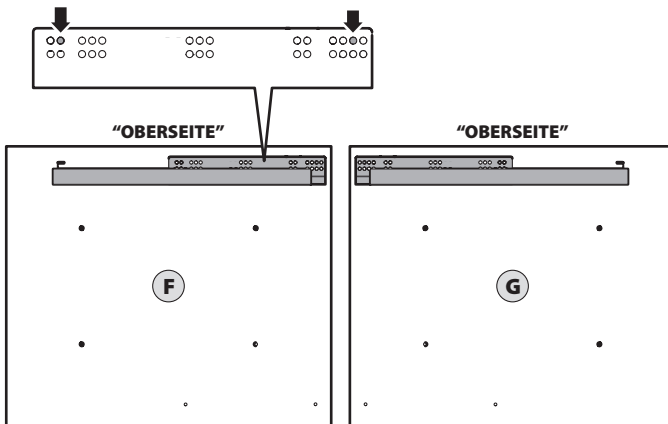
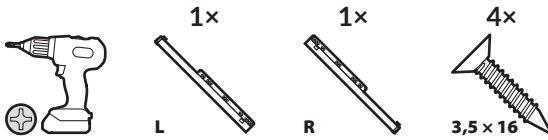

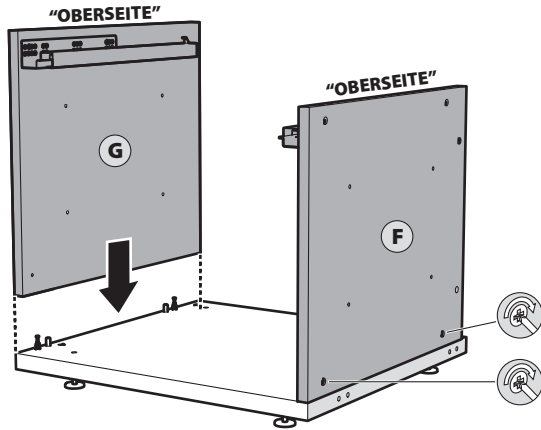

8

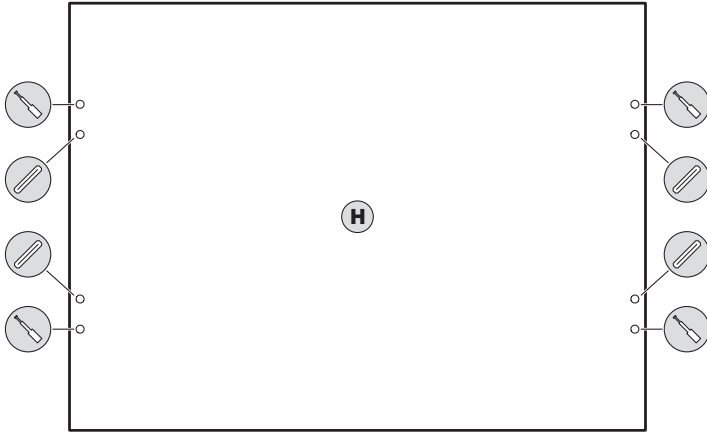
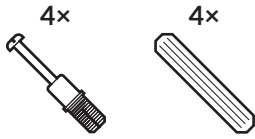

9

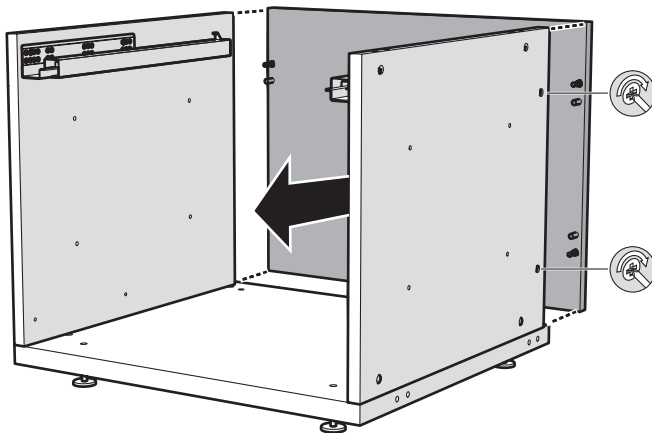

10

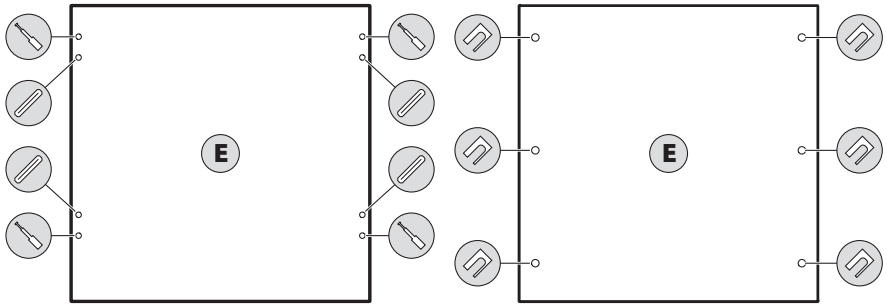
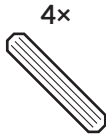
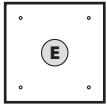

11

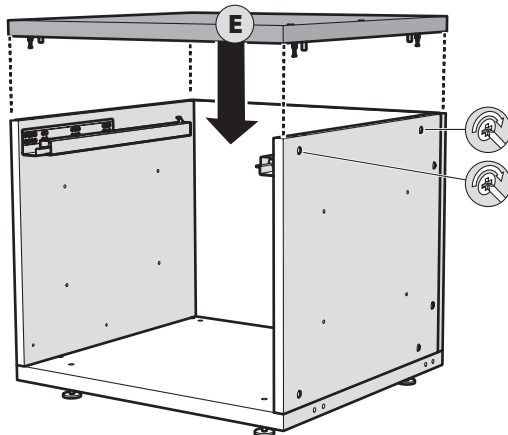

12

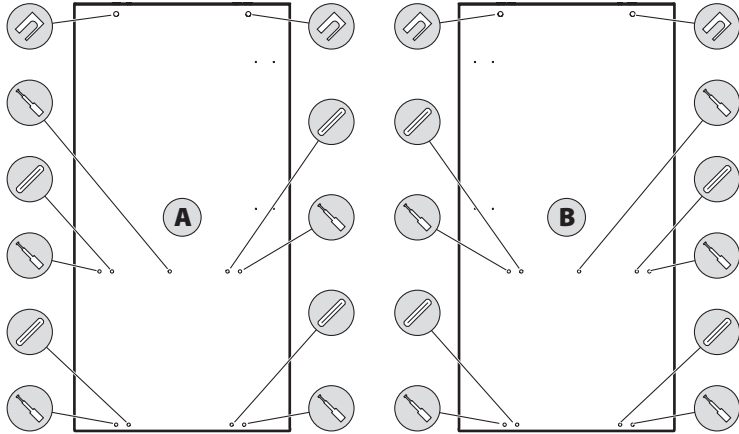
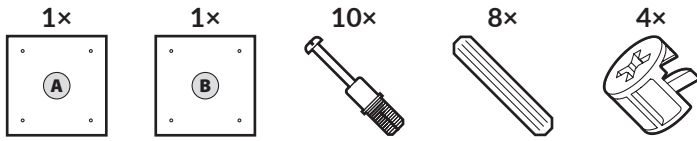

13

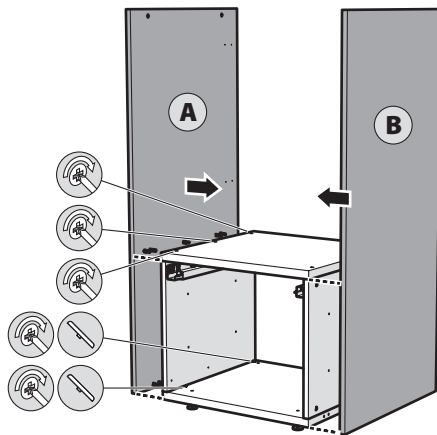
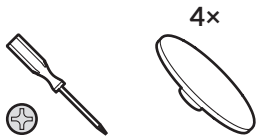

14

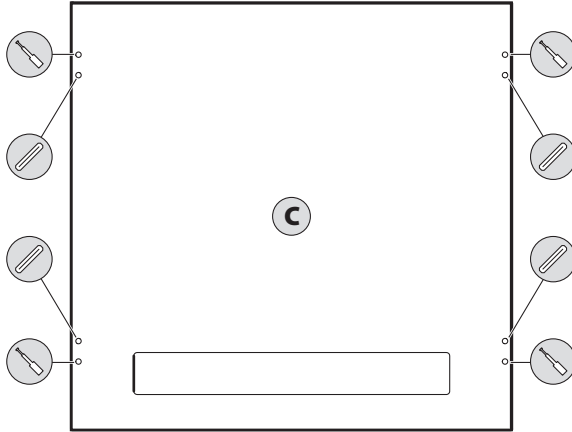
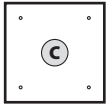

15

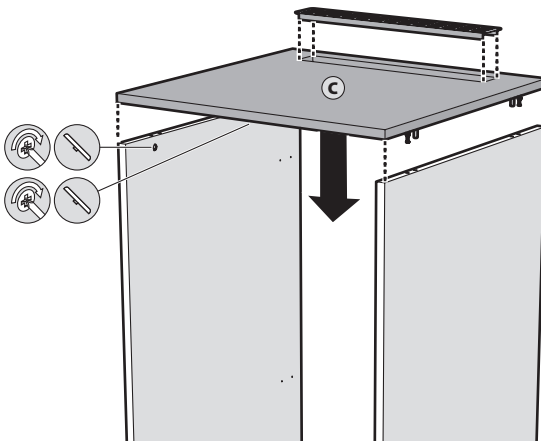
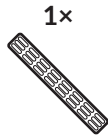

16



1x



L

1x



R

4x



3,5 x 16

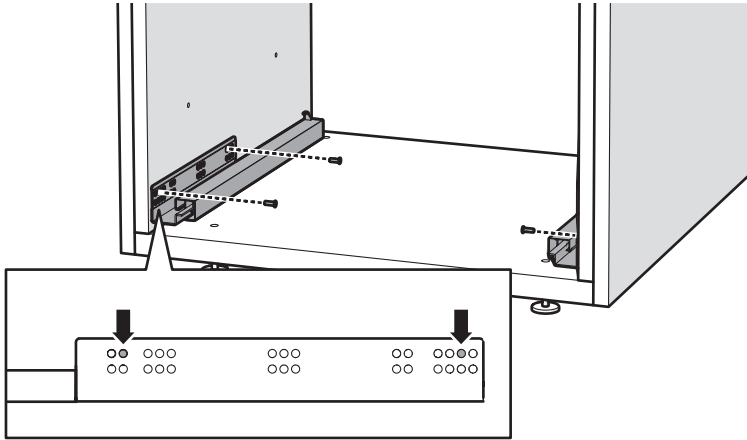

17



8x



3,5 x 30

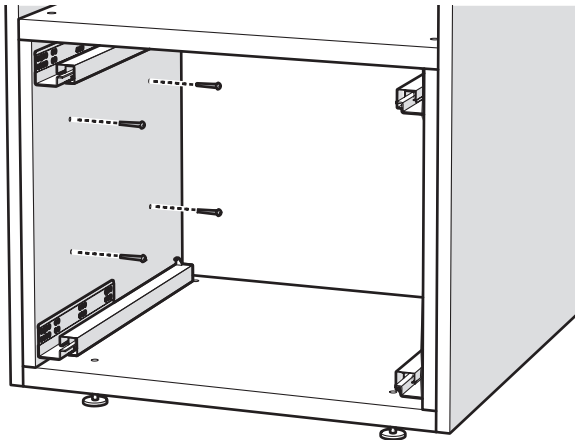

18

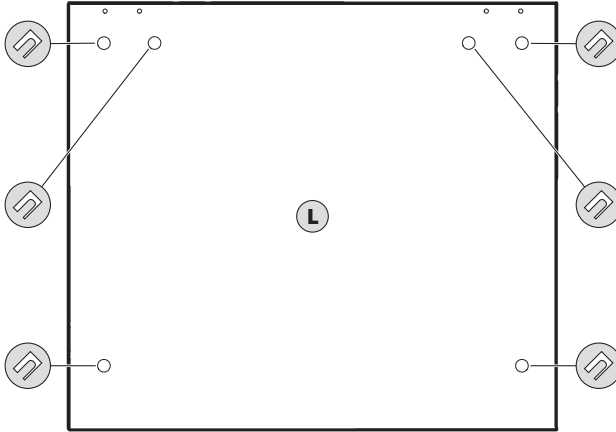
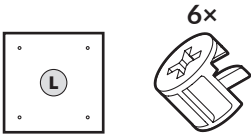

19

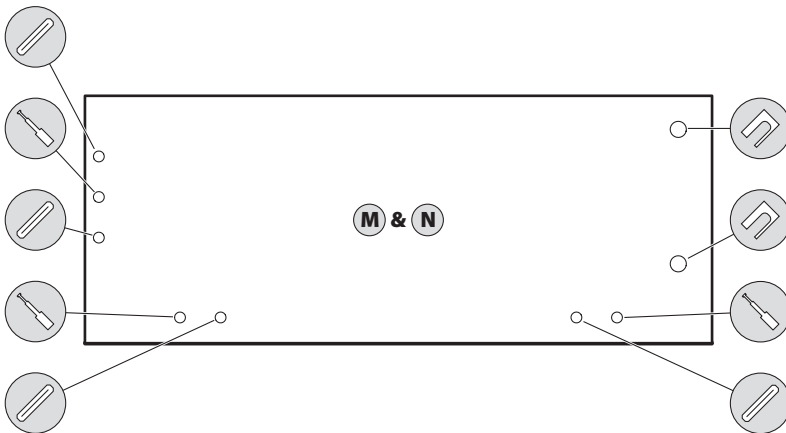
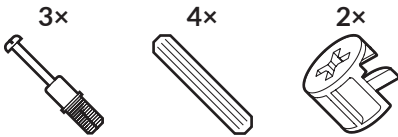

20

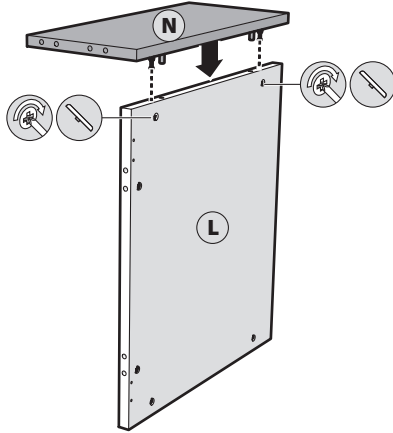
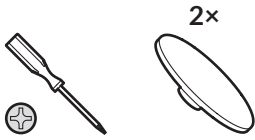

21

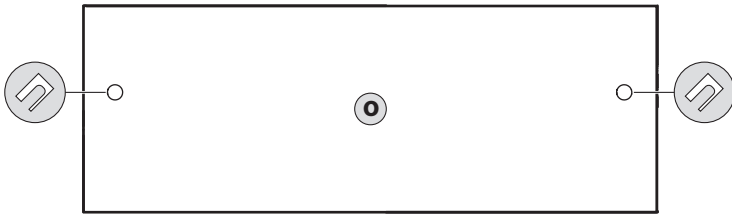
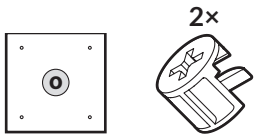

22

1x

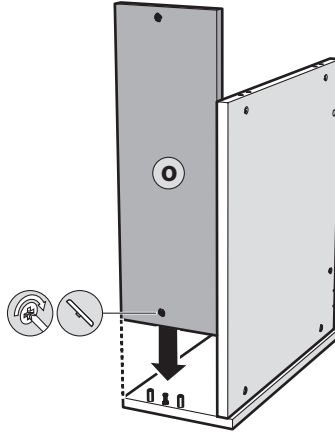

23

3x

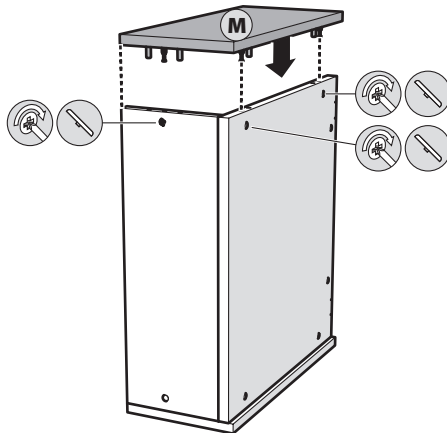

24

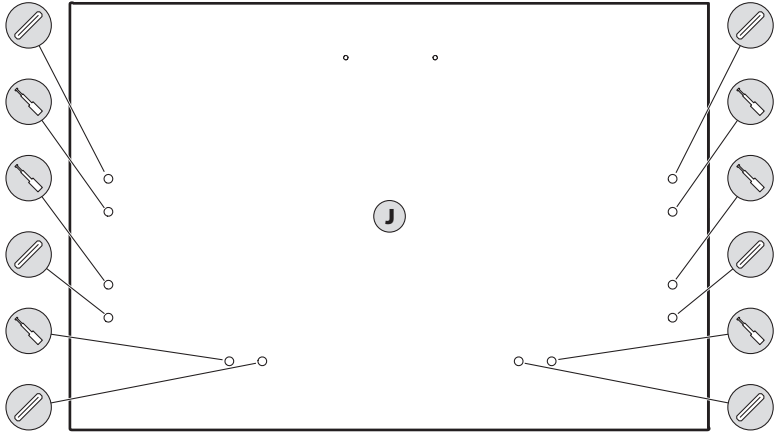
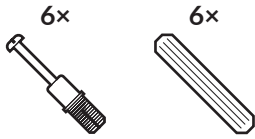

25

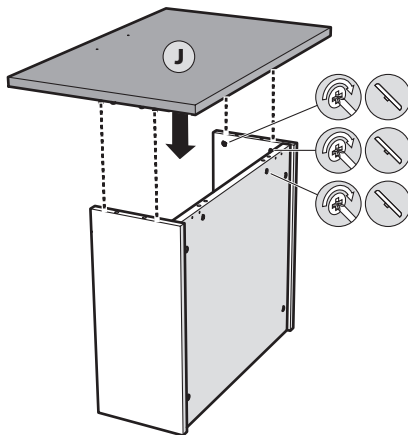
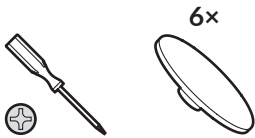

26

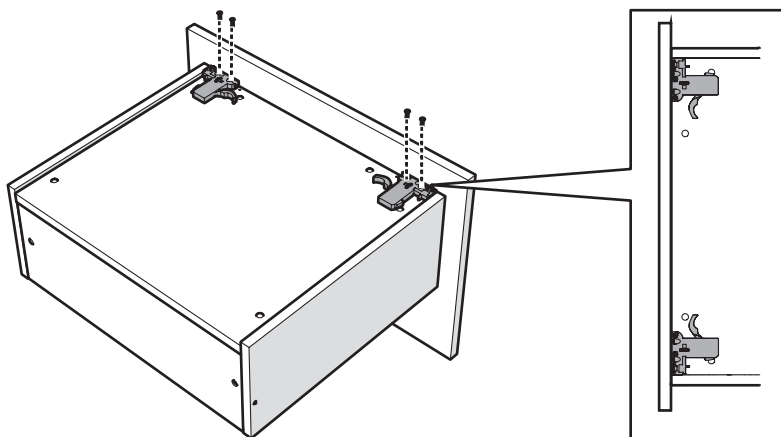
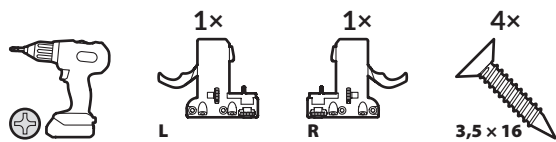

27

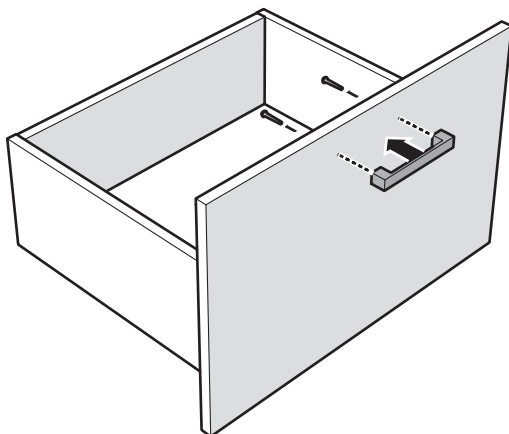
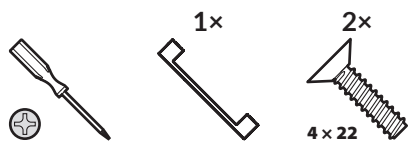

28

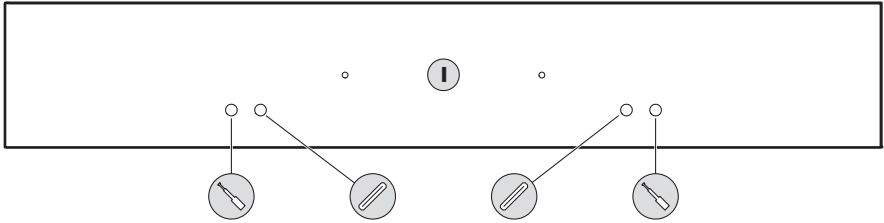
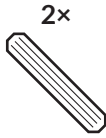
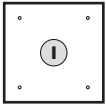

29

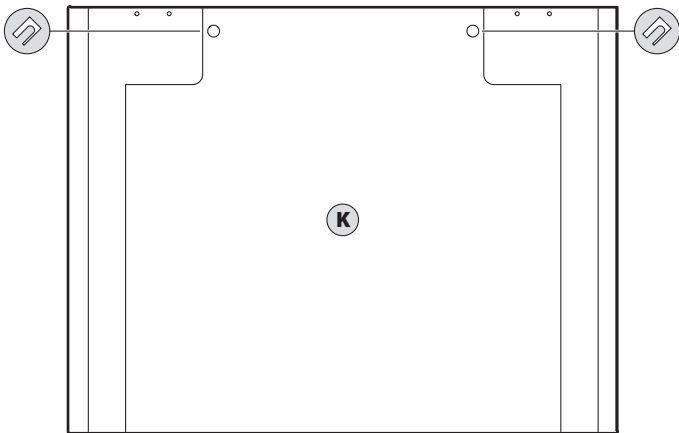
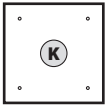

30

2x

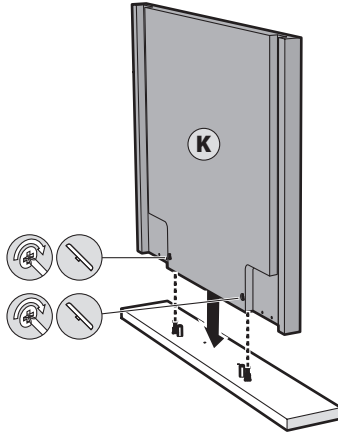

31

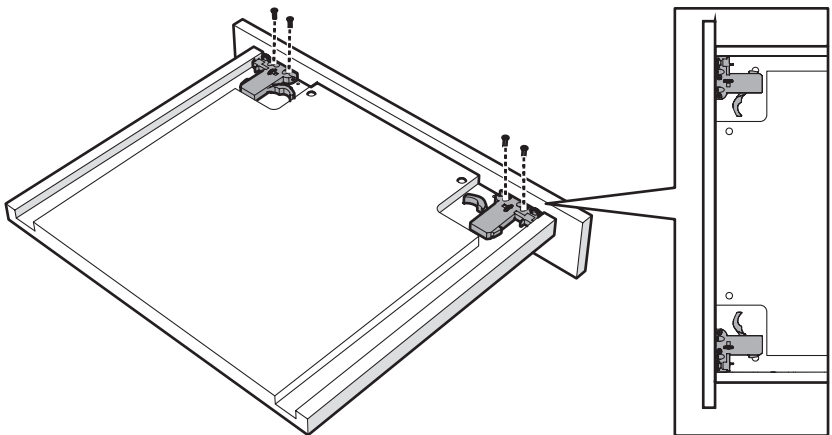
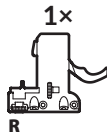
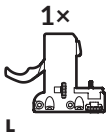

32

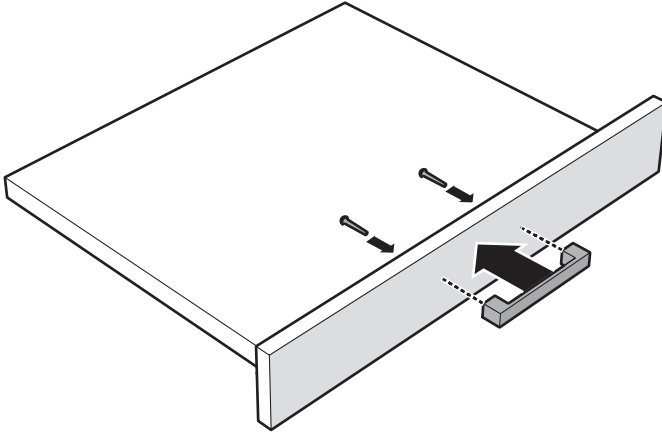
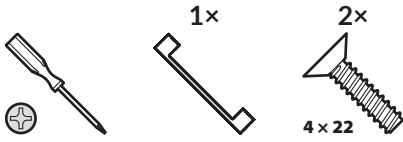

33

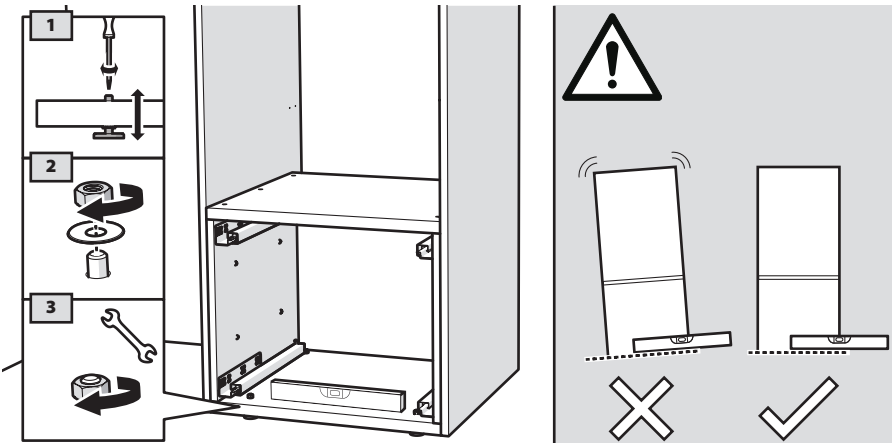

34

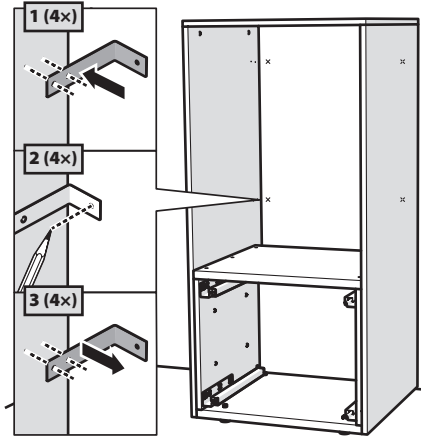
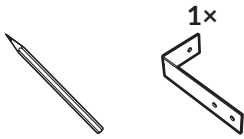

35

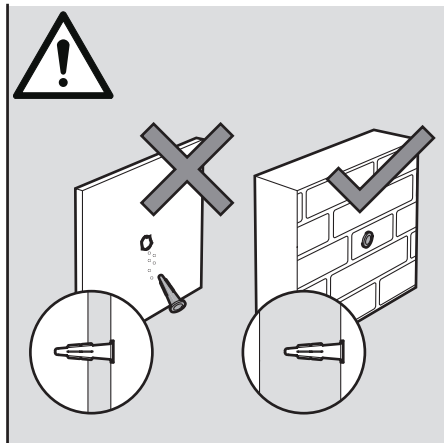
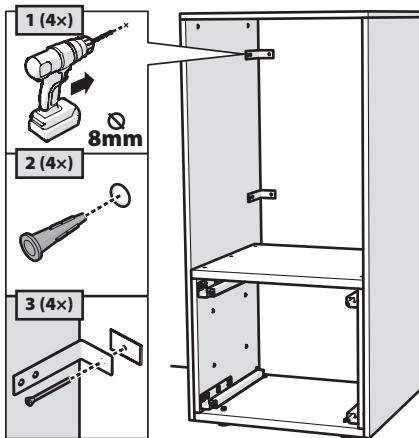

36

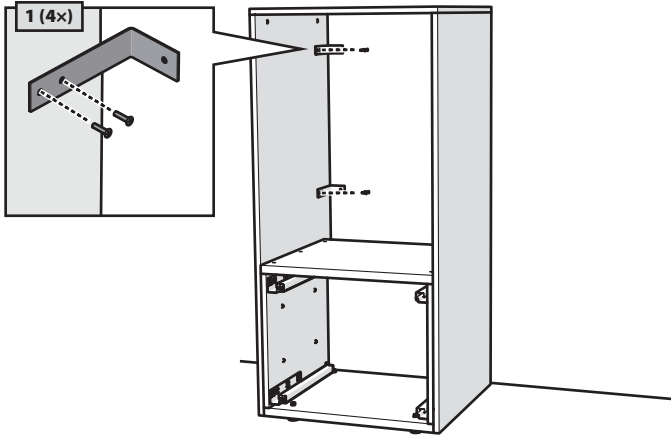

37

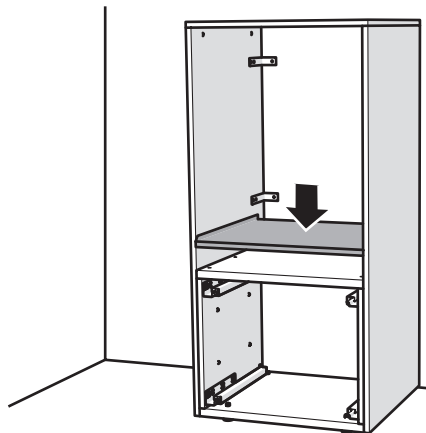

38

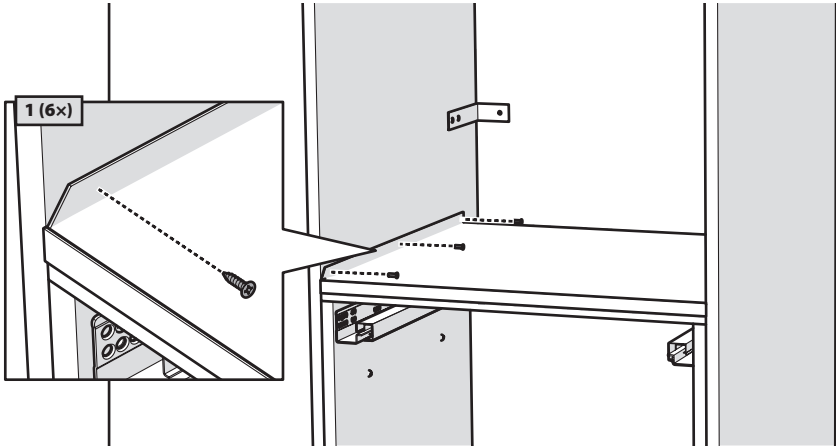
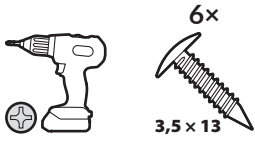

39

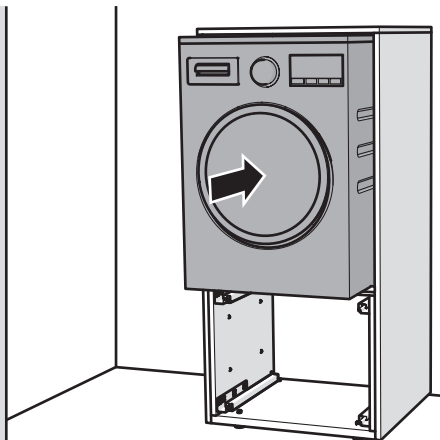
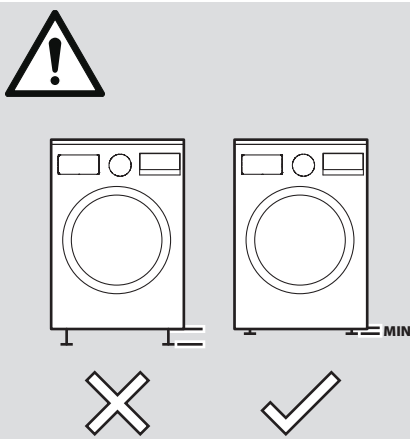

40

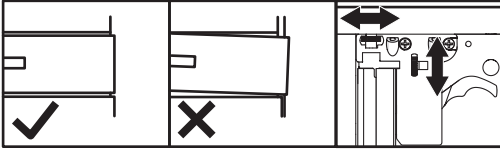
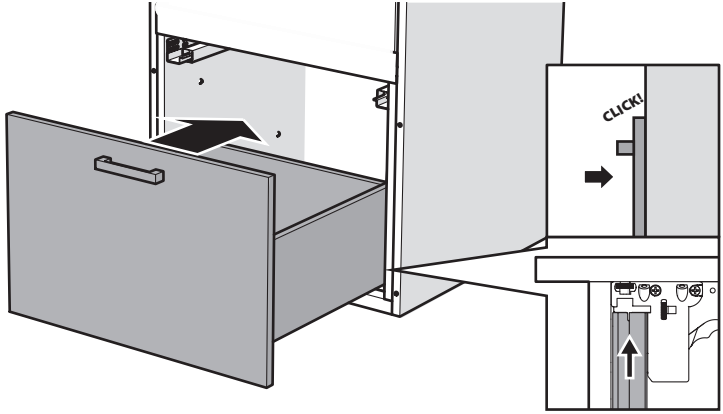

41

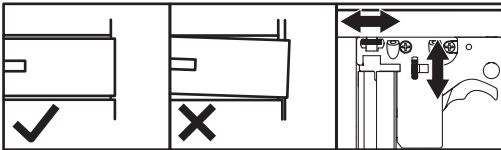
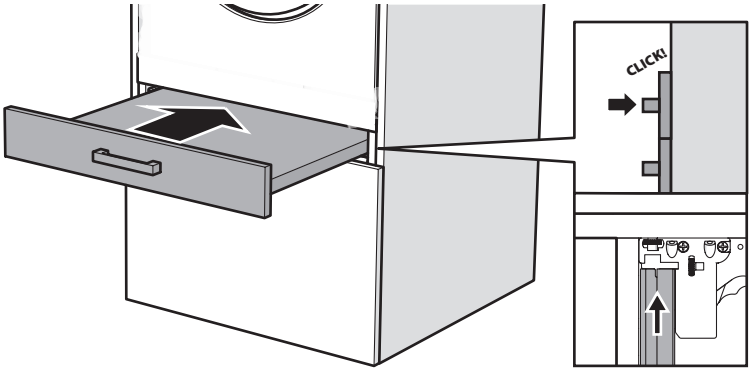

DE WARTUNG

Verwenden Sie für die Reinigung Ihrer Möbel ein weiches Tuch. Wenn das Möbelstück gründlicher gereinigt werden muss, kann das weiche Tuch leicht mit Wasser oder Reinigungsmittel angefeuchtet werden. Verwenden Sie nur für Möbel geeignete Reinigungsmittel. Nachdem Sie die Möbel mit einem weichen, feuchten Tuch abgewischt haben, sollten Sie die feuchten Teile mit einem weichen Tuch trocken wischen. Verwenden Sie keine scheuernden Reinigungsmittel.

EN MAINTENANCE

When cleaning your furniture, use a soft cloth. If the furniture needs to be cleaned more thoroughly, the soft cloth may be lightly moistened with water or detergent, only use detergents suitable for furniture. After wiping the furniture with a soft damp cloth, the wetted parts should be wiped dry with a soft cloth. Do not use abrasive cleaning agents.



NL ONDERHOUD

Gebruik bij het reinigen van uw meubel een zachte doek. Als de meubels grondiger moeten worden schoongemaakt, dan mag de zachte doek licht bevochtigd worden met water of een schoonmaakmiddel. Gebruik alleen schoonmaakmiddelen die geschikt zijn voor meubelen. Nadat het meubel is afgedaan met een zachte en vochtige doek, dienen de bevochtigde onderdelen droog geveegd te worden met een zachte droge doek. Gebruik geen schurende schoonmaakmiddelen.

FR MAINTENANCE

Pour nettoyer vos meubles, utilisez un chiffon doux. Si le meuble doit être nettoyé plus en profondeur, le chiffon doux peut être légèrement humidifié avec de l'eau ou du détergent, n'utilisez que des détergents adaptés aux meubles. Après avoir essuyé le meuble avec un chiffon doux et humide, les parties mouillées doivent être essuyées avec un chiffon doux. N'utilisez pas de produits de nettoyage abrasifs.

Waschmaschinenschränkonline

Jurgensstraße 7A

47574 Goch, Germany

☎ +49 21197633910

✉ info@waschmaschinenschränkonline.de

Wasombouw B.V.

Frankrijkstraat 3

5171 PR Kaatsheuvel, The Netherlands

☎ +31 85 060 52 58

✉ info@wasombouw.nl